

Model 550e

Semi-Automatic Round Product Labeler

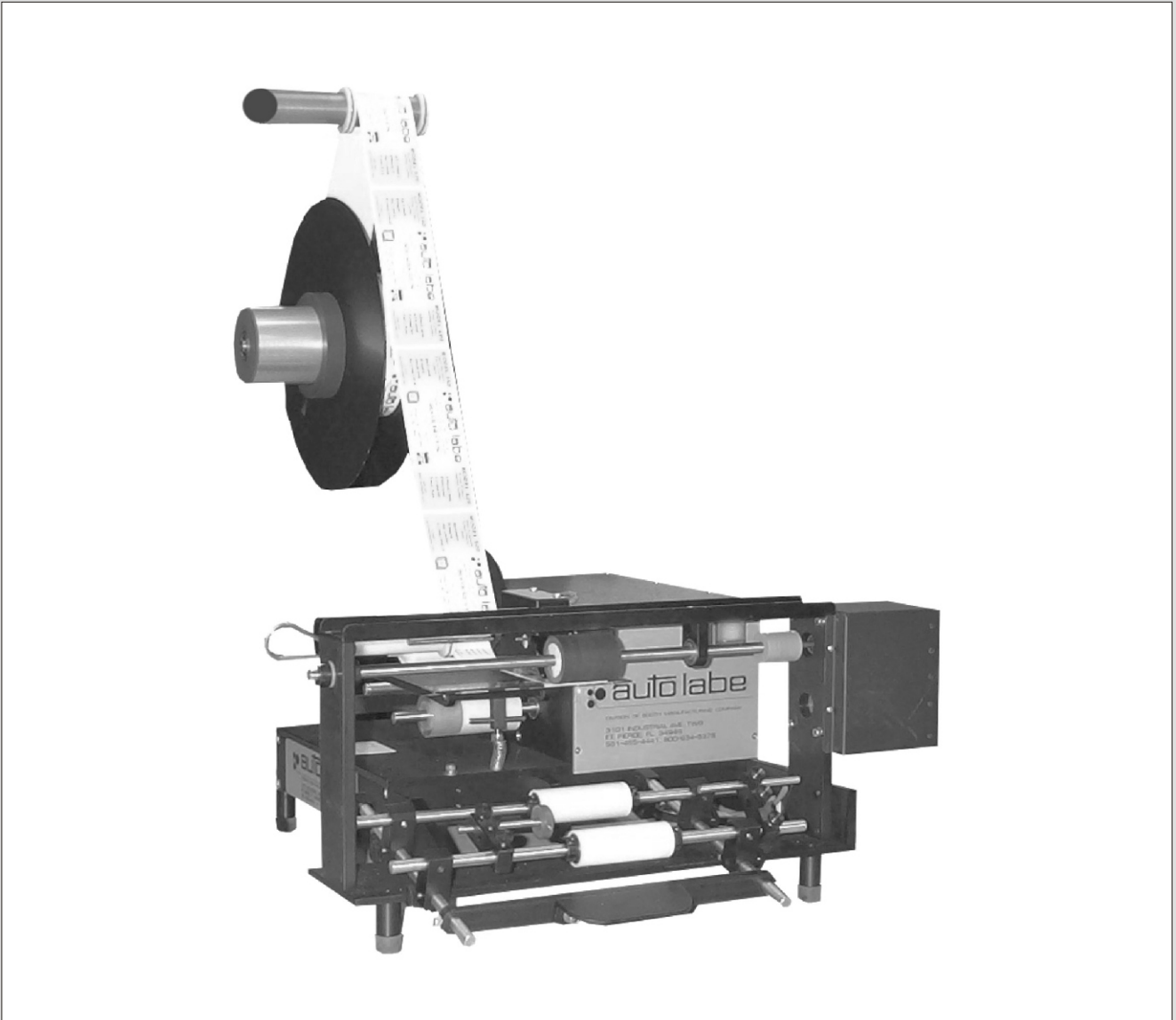

 **auto labe**

MODEL 550e

Toll Free 800-634-5376

MODEL 550e

The Model 550e Semi Automatic Round Product Labeler is designed to be one of the most trouble free, reliable machines available in the industry. The simplistic design allows operators quick changeovers from product to product while also maintaining consistent, accurate label placement.

Features:

- Very economical for small production runs.
- Cost effective transition from manual labeling to semi-automatic labeling.
- Maintains consistent label registration.
- Accurately places labels on round products from 3/8" to 4" diameter.

Specifications:

Equipment Dimensions:

20"W x 30"L x 26"H

Equipment Weight:

40 lbs/19kg (approx.)

Electric Requirements:

115 VAC 60 Hz/5 AMP
(International voltages are available)

Label Specifications:

Standard 5" Web Width/ 10" Roll with 3" Core 1/8" Die Cut, Pressure Sensitive

Options:

- Hot Stamp Imprinters
- Photo Electric Label Sensor.
- Spare parts kits
- Gallon Modification
- Wide Label Kits

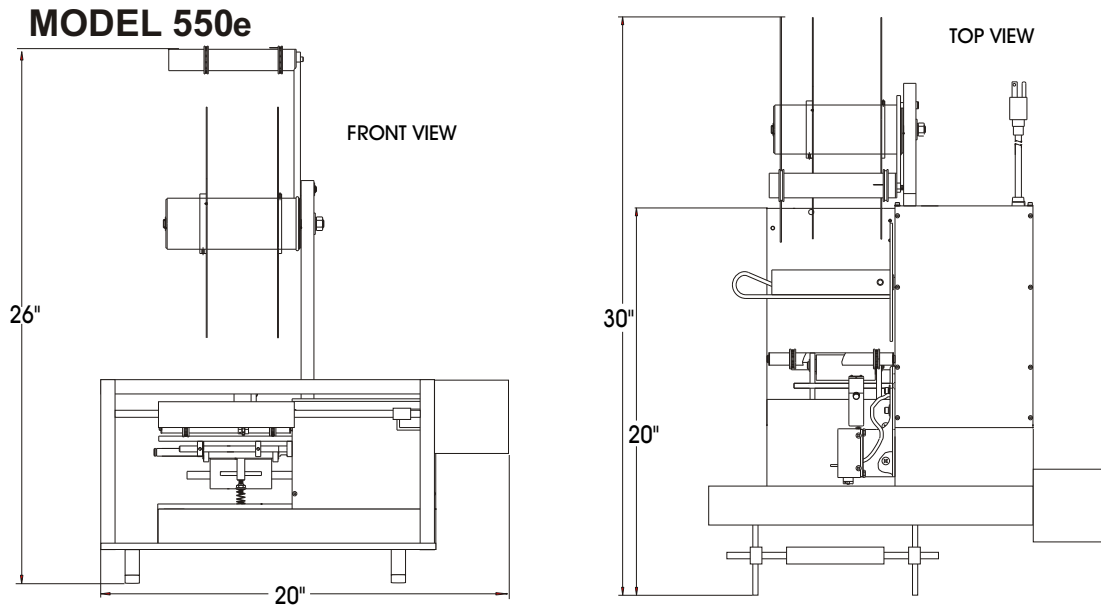

Over 35 years of commitment to quality and innovation
in the Pressure Sensitive Labeling Industry



DIVISION OF BOOTH MANUFACTURING COMPANY

3101 Industrial Avenue Two, Fort Pierce, Florida 34946

Toll Free 800-634-5376 • 772-465-4441 • FAX 772-465-5177

www.autolabe.com e-mail: sales @autolabe.com



DISTRIBUTED BY:

