

Model 110S Stepper Control Label Applicator



**Stepper
Control**

 **auto labe**

MODEL 110S

Toll Free 800-634-5376

MODEL 110S

The Model 110S stepper control label applicator is designed for exceptional label placement accuracy and reliability in medium speed labeling applications. The Model 110S is available with speed following capabilities for applications with varying line speeds. The 110S is designed to provide years of reliable, trouble free operation.

Features:

- Reliable, maintenance free stepper motor drive
- Exceptional label placement accuracy
- Photo electric label sensing
- Left and right hand models available
- Speed following capabilities for varying line speeds

Specifications:

Speed:

Up to 1200" per minute

Web Width:

Up to 6.5"

Electric Requirements:

110 VAC 60 Hz/5 AMP

Equipment Weight:

29 lbs/13kg (approx.)

Equipment Dimensions:

15"W x 23"L x 24"H
(Applicator only)

Options:

- Adjustable heavy duty stands
- Photo electric product sensor.
- Hot stamp imprinters
- Conveyor systems
- Encoder interface
- Spare parts kits
- Web monitoring systems

MODEL 110S RH

(right hand)

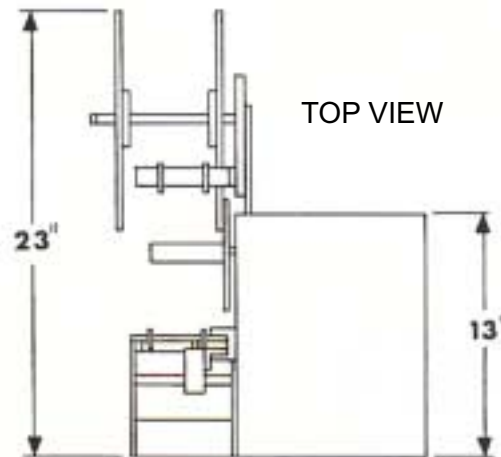
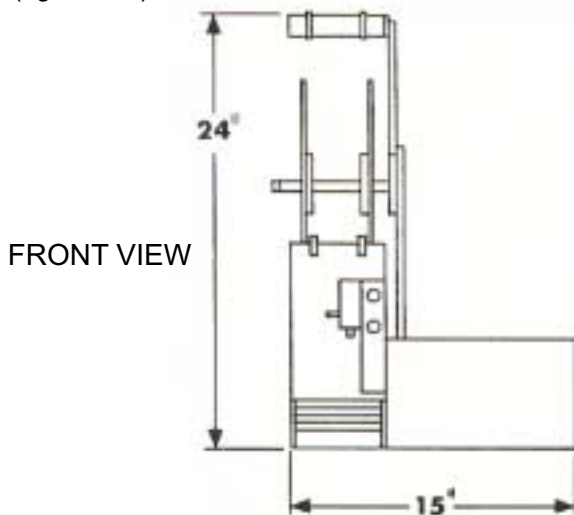

Over 35 years of commitment to quality and innovation
in the Pressure Sensitive Labeling Industry



DIVISION OF BOOTH MANUFACTURING COMPANY

3101 Industrial Avenue Two, Fort Pierce, Florida 34946

Toll Free 800-634-5376 • 772-465-4441 • FAX 772-465-5177



DISTRIBUTED BY:

